

SUBMERSIBLE  
AERATION

 SFA  
enviro

# AEROSPEED®

SUBMERSIBLE DEGREASING AERATOR

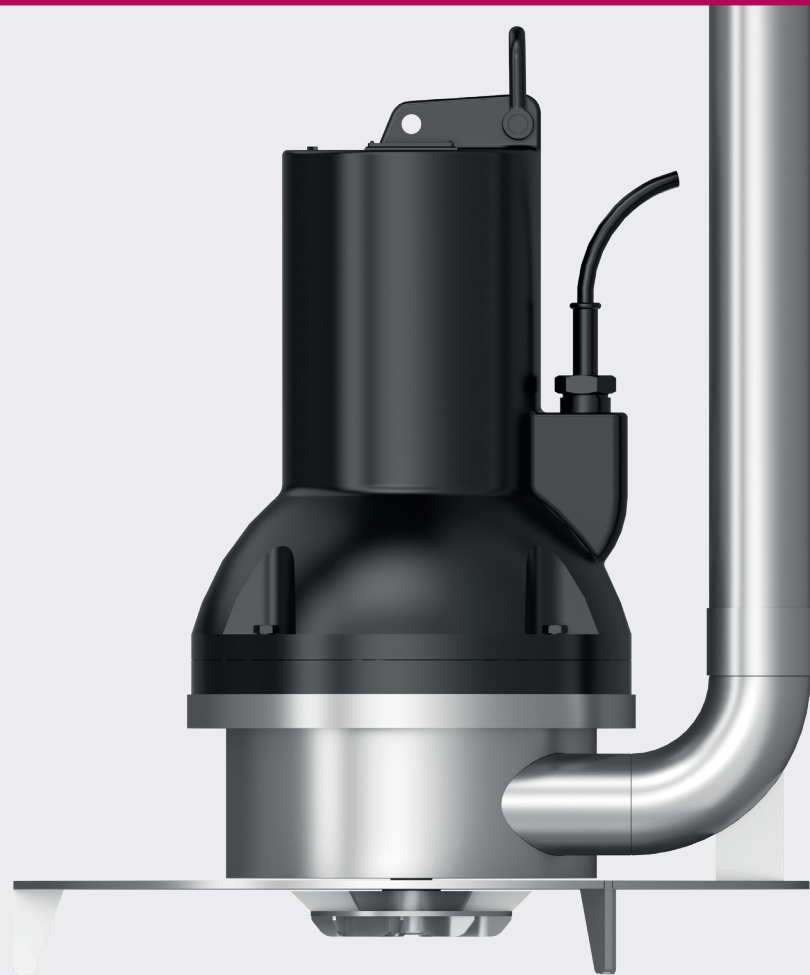

EFFLUENT DEGREASING

 Europelec

## MAIN CHARACTERISTICS

The AEROSPEED is a submersible degreasing aerator that produces microbubbles which in turn causes grease to float onto the liquid surface.

The unit is easy and simple to operate and install.



Motor with output shaft



Motor / frame/ cable



## ADVANTAGES

THE AEROSPEED IS A STAND-ALONE PIECE OF EQUIPMENT READY TO USE WITH NO ANCILLARIES REQUIRED

EQUIPMENT SUITABLE FOR ALL TYPES OF PRE-TREATMENT TANKS AND OIL WATER SEPARATION DUTIES

THE SELF-ASPIRATING SYSTEM OPERATES AUTONOMOUSLY WITHOUT THE REQUIREMENT OF A BLOWER OR INDEPENDENT AIR FEED

COMPACT AND ROBUST EQUIPMENT

MAINTENANCE CAN BE CARRIED OUT WITHOUT DRAINING THE TANK

NOT EFFECTED IN COLD WEATHER

NO AEROSOLS OR SPLASH

EXTREMELY COST EFFECTIVE

## COMPONANTS

- Robust IP68 cast iron motor, coated with epoxy and equipped with a temperature control sensor
- Motor specially adapted to the constraints of operating a submerged degreasing aerator according to Europelec standards
- Stainless steel suction tube
- Stainless steel frame specially designed to optimize the hydraulic flow
- Stainless steel propeller specifically designed to ensure simultaneous mixing and suction of air.

## OPTIONS

- Mounted on tripod
- Silencer
- 316L
- Europelec can supply all the equipment for the aerated degreaser



Motor

Model	Rated power (kW)	Rotation speed (tr/min)	Acceptable immersion depth (m)	Diameter Ø (mm)	Weight (kg)
AEROSPEED 0.75	0,75	About 1500	0,8-1,8	480	56
AEROSPEED 1.1	1,1		0,8-2,1		60
AEROSPEED 1.5	1,5		0,8-2,4		64
AEROSPEED 3	3		0,8-3,2	600	105
AEROSPEED 4	4		0,8-4		111
AEROSPEED 5	5		0,8-4,5		

A STEP AHEAD IN WATER TECHNOLOGY

[sfa-enviro.com](http://sfa-enviro.com)

 [@sfa\\_enviro](https://twitter.com/sfa_enviro)

 **SFA** GROUP

